



REACTOR
Microelectronics

RM3253 Application Information

--5V500mA($\pm 3\%$)

陕西亚成微电子有限责任公司
技术支持部
2010.12



OUTLINE

1. RM3253 Introduction
2. Electronical Characteristic Description
3. Application Circuit
4. BOM List
5. Transformer Parameter



一、RM3253 Description

The RM3253 switch Intergard Circuit cost effectively replace all power supplies, and up to 5W output power based on unregulated isolated linear transformer (50/60HZ). Unlike conventional PWM (pulse width modulation) controllers, they regulate the output voltage in a new method of off-time modulation control. The controller consists of a VCO (voltage control oscillator), Sense and logic circuit, VDD pin, under-voltage lockout circuit, protection for over-voltage, current limited circuit, leading edge blanking, over load protection and fault condition auto-restart. They are ideal low power AC/DC adapter/charger solution for portable devices ,otherwise, its Built-in 800V high voltage BJT and minimal external components .

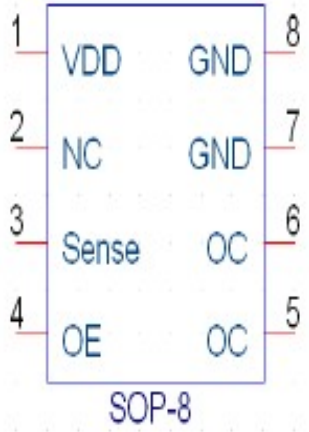

PIN Connection (top view)

Package	Function	Description
 <p>SOP-8</p>	PIN 1: VDD	Power Supply
	PIN 2: NC	Not Connected
	PIN 3: Sense	Current sensor, it senses the voltage via a sensed resistor
	PIN 4: OE	Emmitter Pin of the power BJT switch.
	PIN 5, 6: OC	Output Pin(Connect to switching transformer)
	PIN 7, 8: GND	Ground



二、Electronical Characteristic Description

Item	Conditions	MIN.	TYP.	MAX.	Unit
Supply Voltage					
Operation Voltage			21		V
Turn-on Threshold Voltage	VDD ON	11	12	13	V
Turn-off Threshold Voltage	VDD OFF	5.5	6	6.5	V
Over-voltage Thershold	Vovp		28	30	V
Oscillator					
Operation Frequency		45	50	55	KHZ
Current Sensing					
Leading Edge Blanking		250	300	350	nS
Current Sense Detection Voltage	VDD=15V	0.45	0.5	0.55	V



三、Application circuit

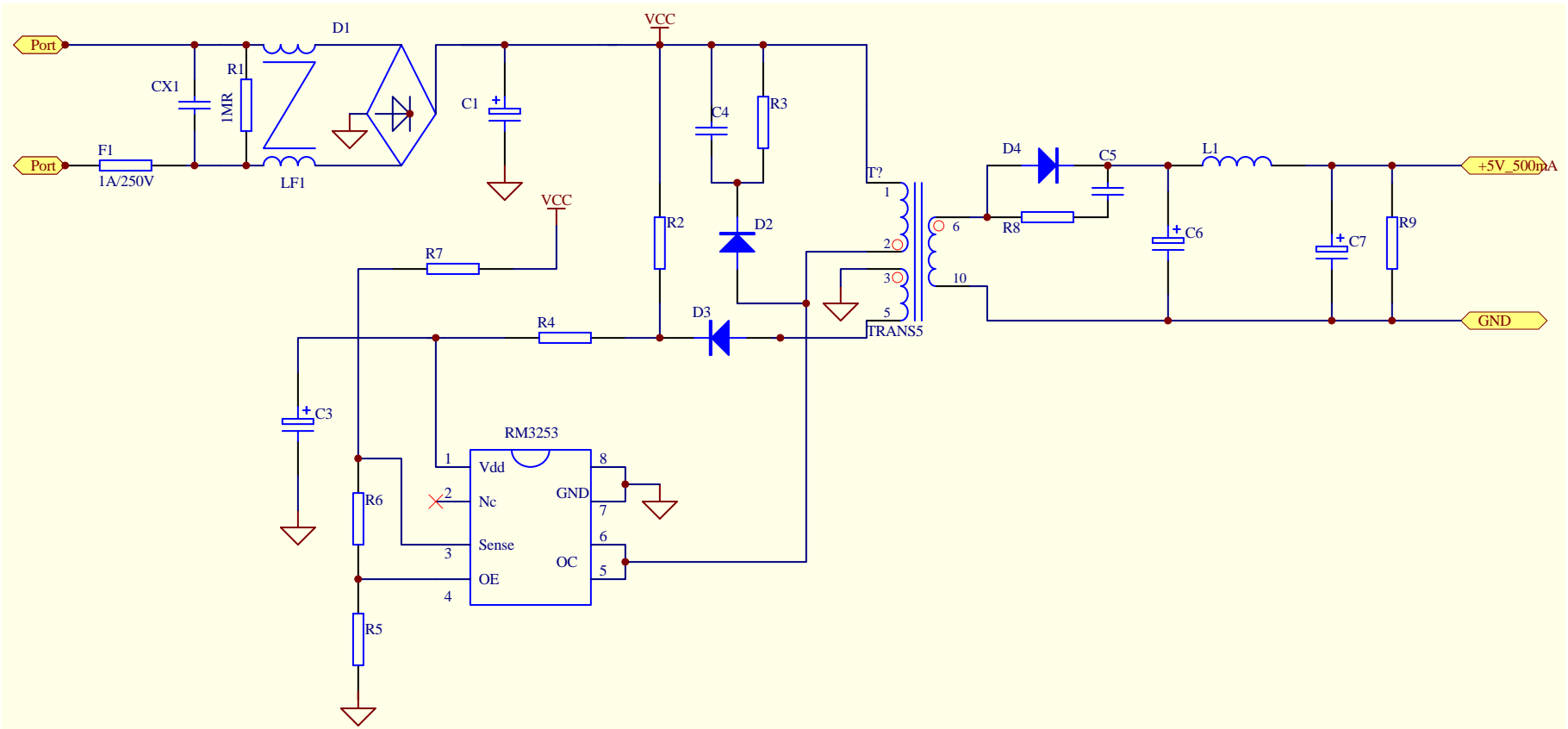



四、BOM LIST

P/N	Description	NO.	Package	Supplier
CX1	0.1uF 275V	1	DIP	
C1	10uF 400V	1	DIP	
C3	1uF 50V	1	DIP	
C4、C9	1nF 1KV	2	DIP	
C6、C7	1000uF 10V	2	DIP	
R2	3M 5% 0805	1	SMD	
R3	100K 5% 0805	1	SMD	
R4	0R 5% 0805	1	SMD	
R5	1.8R 1% 1/2W	1	DIP	
R6	2.7K 5% 0805	1	SMD	
R7	7.5M 5% 0805	1	SMD	
R8	15R 5% 0805	1	SMD	
R9	220R 5% 0805	1	SMD	
D1	Z647	1	SMD	
D2、D3	FR107	2	DIP	
D4	SR360	1	DIP	
LF1	色环电感1mH	2	DIP	
L1	22uH 2A	1	DIP	
F1	1A 250V	1	DIP	
T1	Transformer	1	DIP	
U1	RM3253	1	SMD	Reactor

五、Transformer

RM3253(5V_500mA)变压器参数

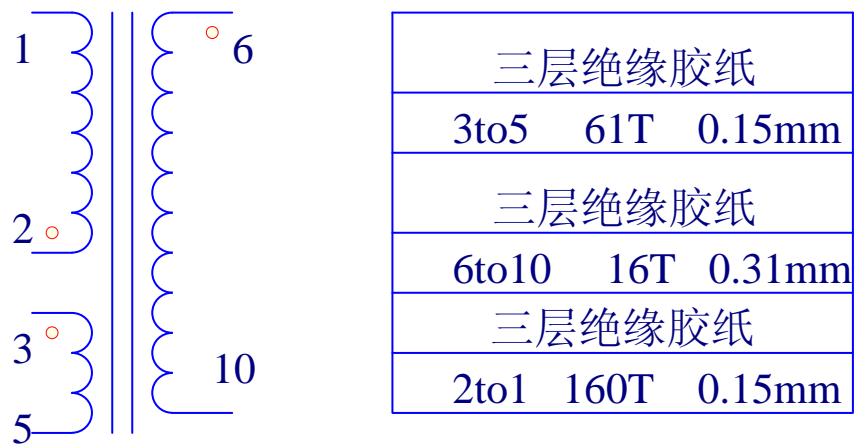

Core:PC40EE13立式, $L_p=3.5\text{mH}$;



六、 Test Report-Test Condition and Test SPEC.

Description	MIN	TPY	MAX	Test Data	Result
Input					
Voltage Frequency	90V 50hz		265V 60hz	85V-265V	PASS
Output					
Voltage	4.85V	5V	5.15V		PASS
Current	500mA				PASS
Load regulation	-3%		3%	2%	PASS
Power		2.5W		2.485W	PASS
Efficiency					
Energy Star(5)				69.18%(avg.)	PASS



Test Data

Line Regulation

Test Condition: Vin=90V-265V, Iload=0A

Vin(V)	90	115	185	220	235	265
Vout (V)	5.05	5.05	5.04	5.04	5.04	5.04

Line regulation: 0.2% ; LG (MAX) : ±2% ; Result: **PASS** ;

Test Condition: Vin=85V-265V, Iload=Iout (max)

Vin(V)	90	115	185	220	235	265
Vout (V)	4.99	4.98	4.95	4.95	4.95	4.96

Line regulation: 0.8% ; LG (MAX) : ±2% ; Result: **PASS** ;

OCP

Vin(V)	90	115	185	220
OCP(A)	0.87	0.88	0.84	0.79
Result	PASS	PASS	PASS	PASS

Notice: Iocp=(1.3-1.8) Iout (max) ;



Test Data

Efficiency

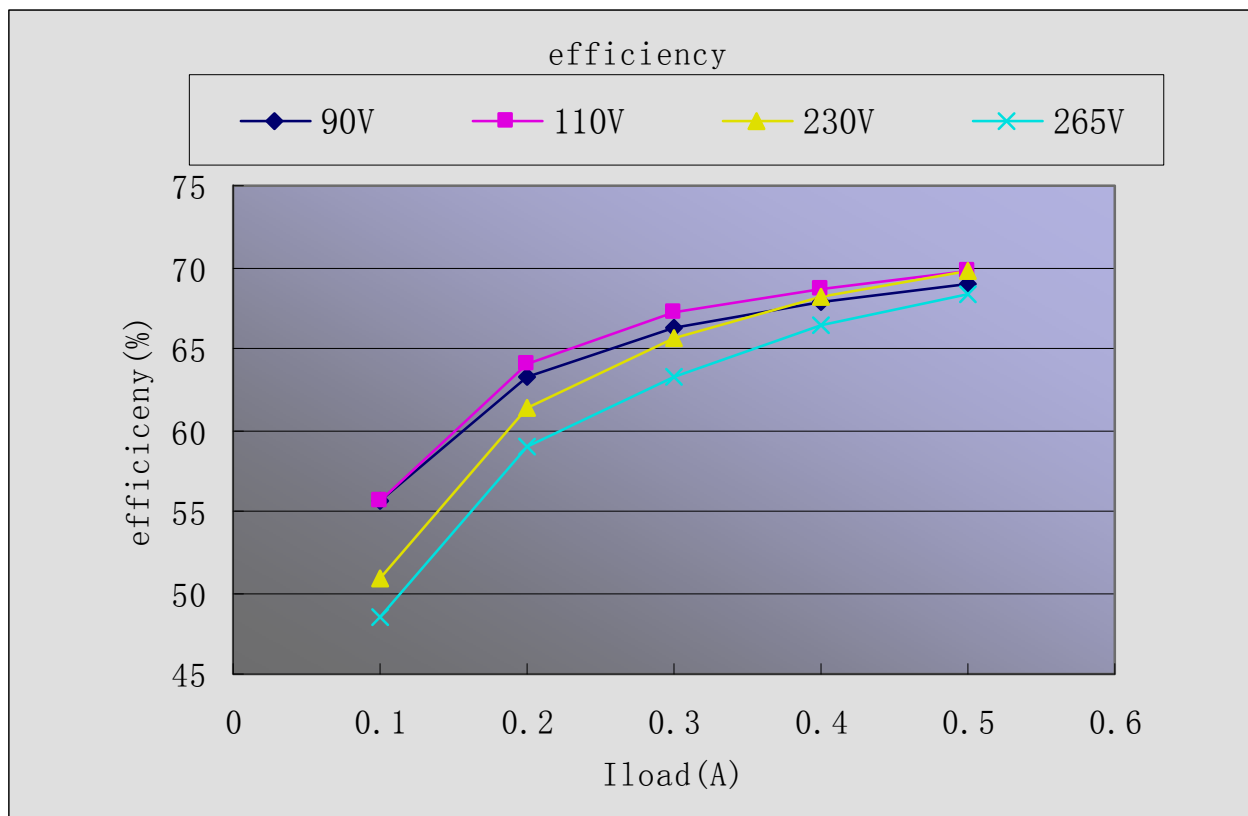



REACTOR
Microelectronics

DEMO Photo

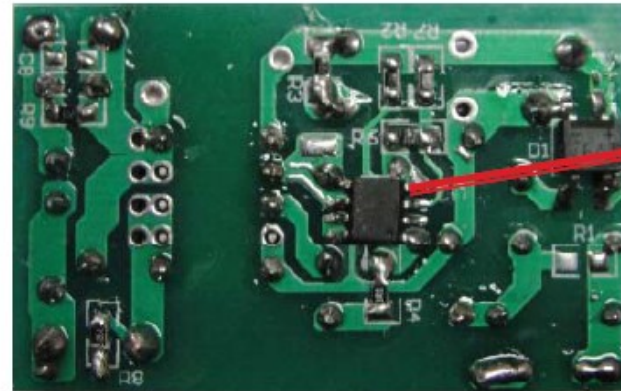
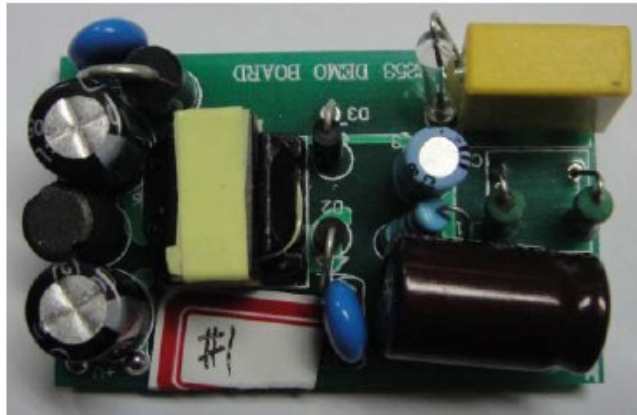



REACTOR
Microelectronics

THE END